



AEROSENTRY PATROL

USER GUIDE

AEROSENTRY PATROL

USER GUIDE

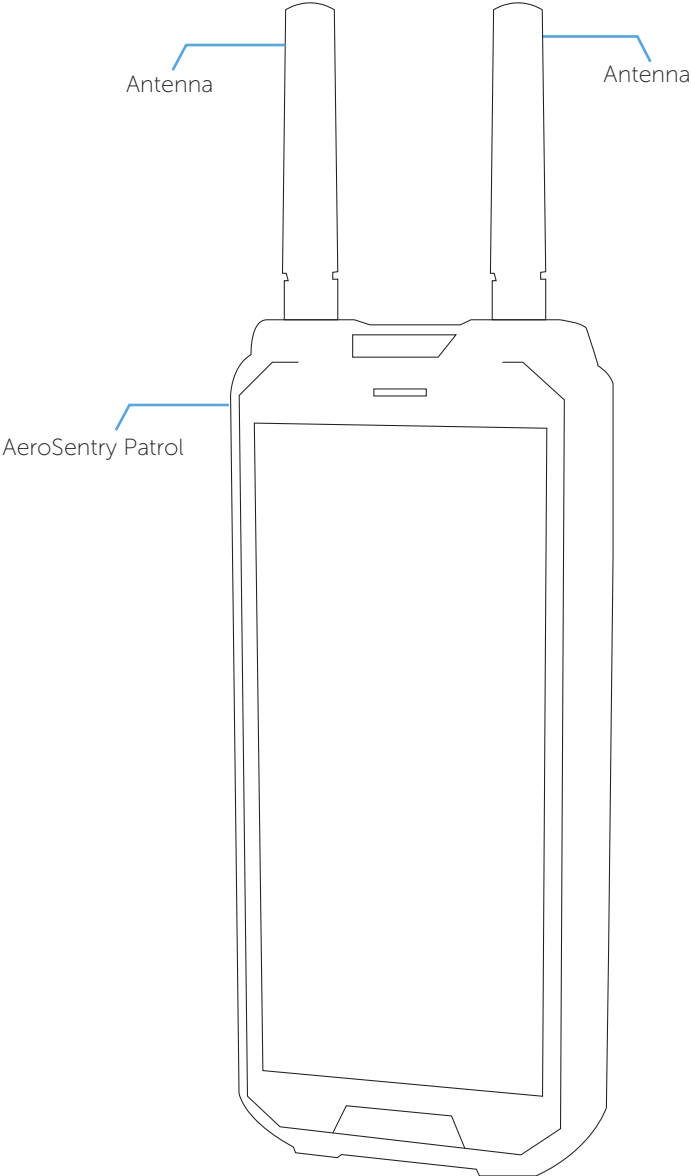

AEROSENTRY PATROL

CONTENTS

1.	Disclaimer & Precautions	1
2.	Product Overview	3
	Core Functional Capabilities	
3.	Equipment Composition & Operating Instructions	6
	3.2.1 Deployment Guidelines	
	3.2.2 Power & Connectivity	
	3.3.3 System Startup	
4.	System Instructions	10
	4.1.1 Main Interface	
	4.1.2 System Status Bar	
	4.1.3 System toolbar	
	4.1.4 Function Menu Area	
	4.1.5 System Operation Bar	
	4.2.1 History List	
	4.2.2 Track Playlist	
	4.2.3 Data Statistics	
	4.2.4 Download	
	4.3.1 General Settings	
	4.3.2 Display Settings	
	4.3.3 Network Settings	
	4.3.4 Alarm Settings	
	4.3.5 Whitelist Settings	
	4.3.6 Location Settings	
	4.3.7 Parameter Settings	
	4.3.8 Application Management	
	4.3.9 About	
	4.4.1 Detection & Positioning Display	
	4.4.2 Whitelist Addition Function	
	4.4.3 Pilot Position Navigation Function	
5.	Product Parameters	38

AERSENTRY PATROL

1. DISCLAIMER & PRECAUTIONS

1.1 | DISCLAIMER

Thank you for selecting the AeroSentry Patrol handheld detector. Before deploying this device, please read this manual carefully to ensure correct setup and safe usage.

Failure to operate the AeroSentry Patrol in line with the guidance provided may result in reduced performance or damage to the equipment. Please note that this manual reflects the current software version at the time of publication; updates or changes may occur without prior notification following future firmware releases.

1.2 | SAFETY PRECAUTIONS

Use of the AeroSentry Patrol handheld detector implies full acceptance of the terms set out in this manual. The device must not be opened, modified, or disassembled by unauthorised personnel under any circumstances.

To ensure safe and reliable operation, the following precautions must be observed:

Software Integrity

Do not install any third-party or unauthorised software on the AeroSentry Patrol. Only system-approved applications should be used. Damage caused by unsupported software installations is not covered under warranty.

Battery Management

Charge the device promptly when a low battery warning is displayed to preserve battery health.

If the device is not in regular use, it must be charged at least once per month to prevent battery depletion and potential failure.

Charging Safety

Never charge the device in damp or wet conditions. Do not handle the charger with wet hands.

Use only the original supplied charger or a compatible Type-C charger approved for this device. Use of unapproved charging equipment may result in malfunction or fire.

AERSENTRY PATROL

Do not operate the device while it is charging, as this may lead to overheating or battery damage.

In the event of a power outage while charging, disconnect the charger to avoid potential surge damage.

System Configuration

Do not alter system date or time settings arbitrarily, as this may affect system functionality.

The device must not be disassembled or tampered with internally.

Operational Compliance

The AeroSentry Patrol must only be used within the legal framework applicable in your country or region. The user is responsible for ensuring lawful use.

Avoid deploying or storing the device in locations exposed to direct sunlight, extreme temperatures, high humidity, corrosive environments, strong magnetic fields, or high levels of static electricity.

Thermal Protection

Should the device overheat, built-in safety mechanisms will activate to preserve user safety and system performance. These include dimming the display, reducing processing speeds, or pausing charging. These are normal safeguards and will self-resolve once the device cools.

Physical Protection

Avoid dropping, compressing, or subjecting the unit to impact, which may result in hardware damage.

During charging, the device may automatically reboot when the charging cable is inserted or removed. This is normal and will be addressed in future firmware updates.

Battery Temperature Tolerance

The lithium battery operates best between 5°C and 35°C. Usage below 0°C may temporarily reduce battery life, cause shutdowns, or prevent startup.

Full functionality will return once the device is brought back within the recommended operating temperature range.

AERSENTRY PATROL

2. PRODUCT OVERVIEW

2.1 | PRODUCT INTRODUCTION

The AeroSentry Patrol is a compact, handheld drone detection device engineered to deliver real-time intelligence on both drones and their operators. Using advanced spectrum analysis and signal classification techniques, the system autonomously detects and decodes radio frequency emissions associated with unmanned aerial systems (UAS), providing critical operational data including drone model, serial number, position, velocity, altitude, flight path, and pilot (remote control unit) location—all without emitting any signals of its own.

Designed for portability and extended field use, the AeroSentry Patrol features a slimline form factor, intuitive user interface, and long-lasting high-capacity battery. It is suitable for a wide range of low-altitude airspace security operations, including use by law enforcement, critical infrastructure security teams, event security, and protective services.

Core Functional Capabilities

1. Passive RF Detection

Operates in a non-emitting, passive mode—monitoring drone transmissions without broadcasting—ensuring discrete and non-disruptive use. Detects both drone type and serial number.

2. High-Fidelity Identification

Capable of distinguishing between multiple drones of the same make and model, even when operating on the same frequency bands.

3. Precise Target Positioning

Provides real-time bearing and positional information on UAS targets using a single handheld device, without requiring triangulation from multiple sensors.

4. Integrated Wireless Intercom

When networked, the device supports real-time push-to-talk (PTT) communication between multiple users. One-touch activation allows intercom

AEROSENTRY PATROL

5. Blacklist/Whitelist Management

Users can assign drones to a blacklist or whitelist via a single-click interface. Whitelisted drones are flagged as trusted and will not trigger alerts, while blacklisted drones prompt a security response.

6. DJI Platform Compatibility

Full support for mainstream DJI drones, including models using OcuSync transmission protocols.

7. Multi-Drone Trajectory Visualisation

Capable of tracking and displaying simultaneous flight paths of multiple UAVs on-screen, with colour-coded visual separation for situational clarity.

8. Intrusion Alerting

Triggers an on-device audible and visual alarm when an unauthorised drone enters the monitored airspace.

9. Remote Controller (Pilot) Geolocation

Detects and indicates the position and directional bearing of the drone operator, facilitating swift ground intervention.

10. Simultaneous Multi-Target Tracking

Supports real-time detection, positioning, and trajectory tracking of ten or more UAVs concurrently.

11. Remote ID (RID) Drone Detection

Identifies drones broadcasting Remote ID (RID) information, displaying a distinct icon for clear recognition.

12. FPV Drone Signal Detection

Detects analogue and digital FPV (First Person View) video transmission signals and supports live RF-based image stream analysis.

13. Data Export and Connectivity

Allows export of detection and decoding logs via Bluetooth, USB, or network connection for further analysis, integration, or archiving.

Note: The above functions can locate the drone as a DJI series model using OcuSync image transmission method.

AEROSENTRY PATROL

2.2 | PRODUCT COMPOSITION & CONFIGURATION

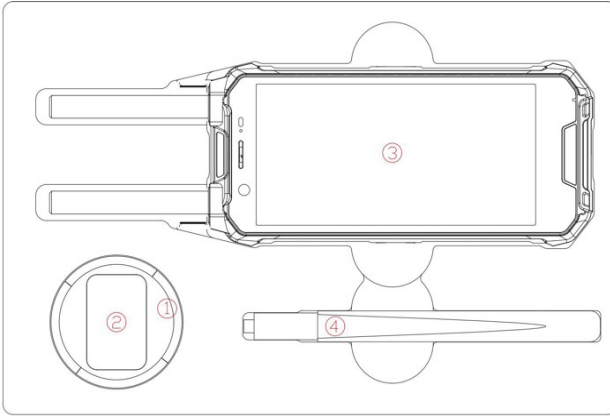

- ① Type-C data cable
- ② AC adaptor
- ③ Device host
- ④ Backup RF

SERIAL NUMBER	NAME	NUMBER	UNIT	NOTES
①	Type-C data cable	1	pcs	
②	Power adaptor	1	pcs	
③	Device host	1	pcs	Including two antennas
④	Backup full frequency RF antenna	1	pcs	Spare

AERSENTRY PATROL

3. EQUIPMENT COMPOSITION & OPERATING INSTRUCTIONS

3.1 | EQUIPMENT COMPOSITION DESCRIPTION



Note:

RF antenna can be replaced and disassembled according to different requirements and can be replaced by a full band antenna with a frequency band of 0-6GHz.

AEROSENTRY PATROL



④ Power switch key

⑤ Intercom button

AERSENTRY PATROL

3.2 | EQUIPMENT COMPOSITION DESCRIPTION

3.2.1 *Deployment Guidelines*

To ensure optimal detection performance, the **AeroSentry Patrol** handheld detector should be operated in open outdoor environments with minimal RF interference and unobstructed lines of sight. The following deployment considerations must be observed:

1. Elevated positions—such as open high ground or rooftops—provide the most effective coverage and signal clarity.
2. Avoid deploying near sources of high radio frequency interference, including mobile phone masts, communication base stations, and electrical substations.
3. Obstructions such as dense woodland, tall structures, or narrow urban environments may impair signal detection and tracking accuracy. Avoid deploying in these areas where possible.
4. Do not expose the device to prolonged direct sunlight during operation, as this may degrade performance or lead to temporary malfunction due to overheating.
5. Use of alternative antenna types may result in variations in detection performance. This is expected and not indicative of device fault.
6. Minor differences in performance may occur between individual units due to manufacturing tolerances—this is considered normal.

3.2.2 *Power & Connectivity*

Power Supply

- The AeroSentry Patrol can be charged using the original power adapter provided, or any compatible charger with a USB Type-C interface that meets standard safety requirements.

AERSENTRY PATROL

Network Access

- The device supports wireless connectivity via Wi-Fi or mobile hotspots for access to online services or updates.
- A SIM card may be installed for mobile network connectivity, enabling standalone operation in the field without reliance on external networks.

3.2.3 *System startup*

To power on the AeroSentry Patrol handheld detector, follow the procedure below:

1. From Powered Off

If the device is completely switched off, press and hold the power button (Key '4' —refer to the equipment diagram in Section 3.1). The system will boot up and automatically launch the main user interface.

2. From Standby Mode

If the device is in standby, a short press of Key '4' will reactivate the system and return the device to the main interface.

Operational Indicator

Once active, the status indicator in the upper left-hand corner of the screen will change from red to green, confirming the device is fully operational and in detection mode. ●

AERSENTRY PATROL

4. SYSTEM INSTRUCTIONS

The AeroSentry Patrol system is structured around three primary operational menus: Detection, History, and Settings. These menus provide access to all core monitoring, data review, and configuration functions.

4.1 | DETECTION

4.1.1 *Main Interface*

Thank you for selecting the AeroSentry Patrol handheld detector. Before deploying this device, please read this manual carefully to ensure correct setup and safe usage.

Failure to operate the AeroSentry Patrol in line with the guidance provided may result in reduced performance or damage to the equipment. Please note that this manual reflects the current software version at the time of publication; updates or changes may occur without prior notification following future firmware releases.

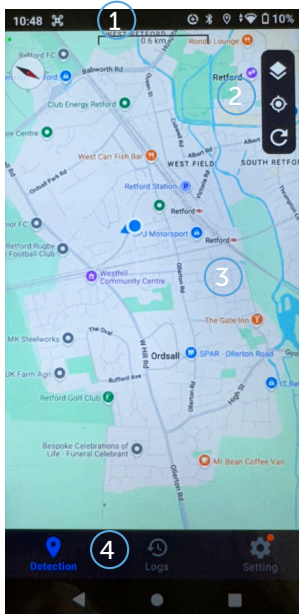

The main interface of the system includes four main areas, as shown in the left figure:

- ① Status bar
- ② Toolbar
- ③ Electronic Map Area
- ④ Function & Setting Area

Figure 4.1 Legend of system main interface

AEROSENTRY PATROL

4.1.2 System Status Bar

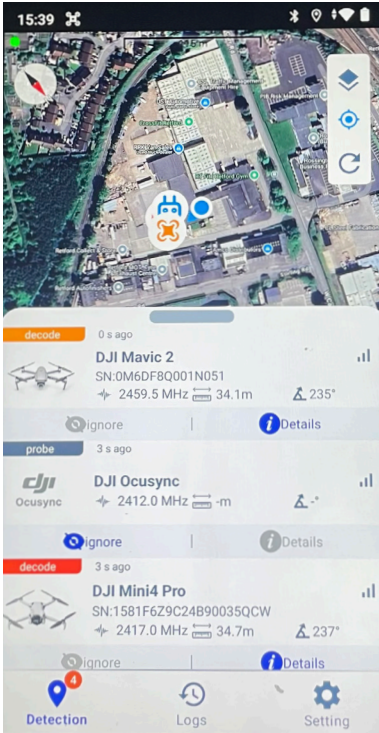

This work area includes time display, application status display, network connection status display, and power display.

Equipment Operation Status Display

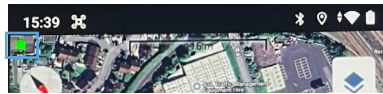

Time Display

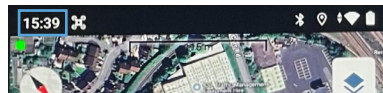

Application Startup Icon Display

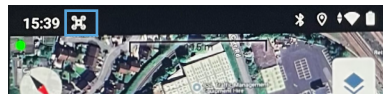

Equipment Power Display

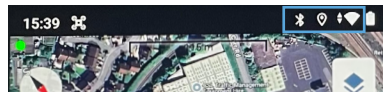
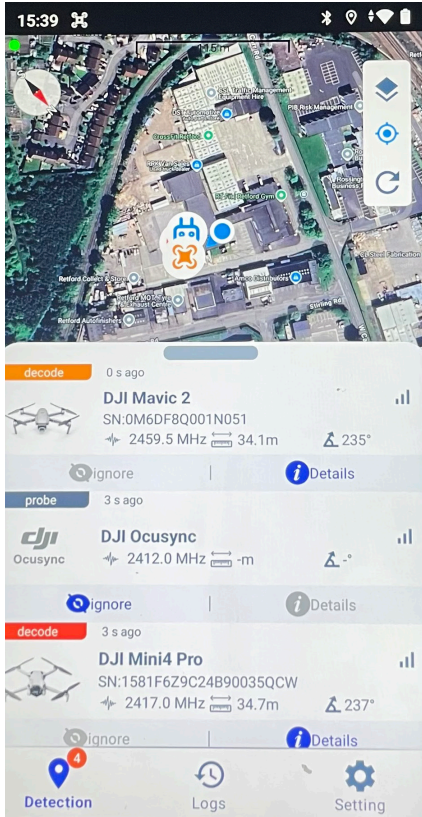

Figure 4.2 System status bar diagram

AERSENTRY PATROL

4.1.3 System Toolbar



This workspace includes map layer switching, map reset, and page refresh.

Map Layer Switch

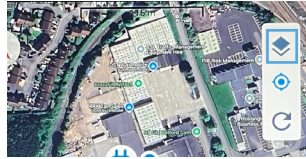

Map Reset

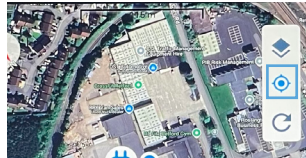

Page Refresh

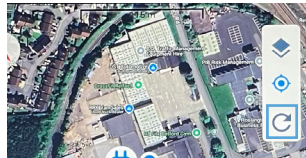

Figure 4.3 System toolbar

Map Layer Switching Tool

The AeroSentry Patrol interface includes a map layer selection tool, offering four different base map options, including satellite and standard views (e.g. Google and Goddard variants). Map data can be downloaded for offline use when connected via Wi-Fi.

Users may manually input longitude and latitude coordinates to define a specific area for offline map download, or use the default option, which captures the currently visible area.

AERSENTRY PATROL

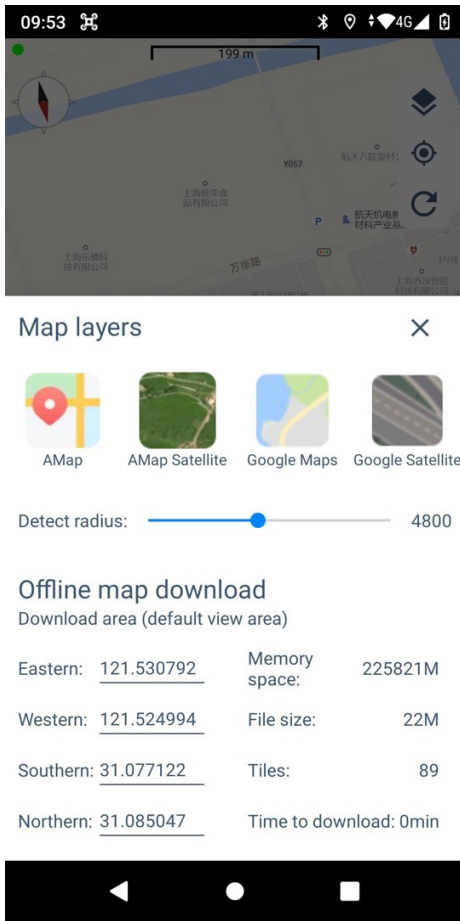

Stand-alone will enter the user into 'map selector' interface.

- 4 map modes are available (including satellite):



Offline maps

The AeroSentry Patrol supports offline map downloads for enhanced field use. Operators can either:

- Manually define a custom area by entering specific longitude and latitude coordinates; or
- Use the default setting to download the currently displayed map area. Before initiating a download, select "Calculate Size" to estimate the file size. To begin the process, click "Start Download"—the progress bar will indicate completion at 100%. If required, the process can be halted at any time by selecting "Stop Download."

Figure 4.4 Map Layer Switching Interface

AERSENTRY PATROL

Map Navigation Controls

- **Single Click** - Clicking the map navigation icon will centre the map view on the current location of the AeroSentry Patrol device.
- **Double Click** - Double-clicking the icon will activate Orientation Mode, allowing the device icon within the electronic map to rotate in line with the physical orientation of the detector. This enables directional pointing towards the

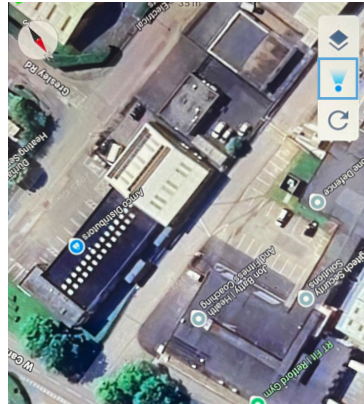
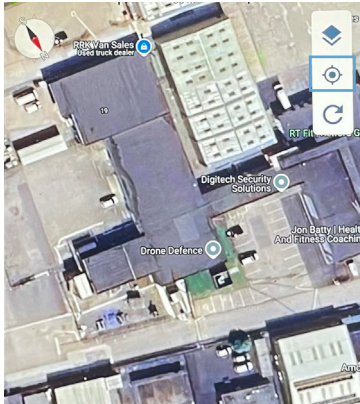

- **Page Refresh Tool** - Click Refresh to refresh the current interface and reload the page.

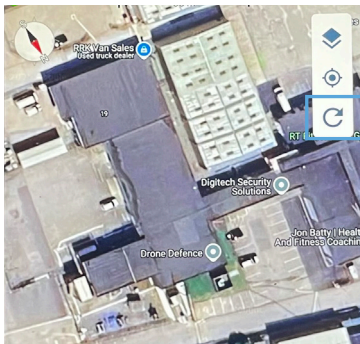

AERSENTRY PATROL

Electronic Map Display

The central section of the AeroSentry Patrol interface is dedicated to the electronic map. This area provides a live visual overview of airspace activity and supports pinch-to-zoom functionality for detailed situational awareness.

When a UAV is detected, the map will display:

- The current location of the AeroSentry Patrol device
- The geolocation of the drone operator (pilot)

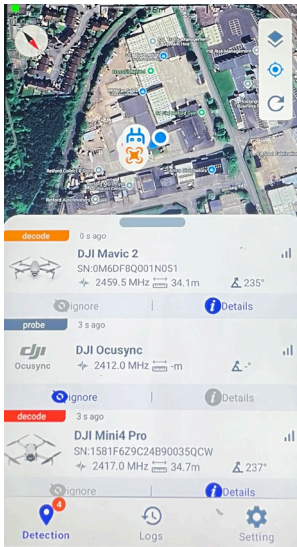

Figure 4.6 UAV detection and positioning interface (left)

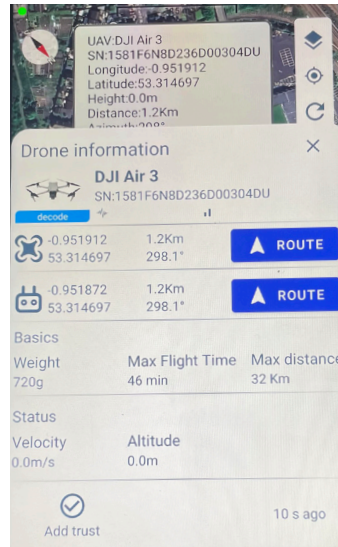

Figure 4.7 Resolution of UAV detection and positioning interface (right)

Note:

When UAV is detected, a red light will flash around the system interface, which can be turned on or off in system settings

AEROSENTRY PATROL

4.1.4 *Function Menu Area*

This control bar includes three options: detection, history and settings. (See 4.3 for software settings and 4.2 for equipment functions)

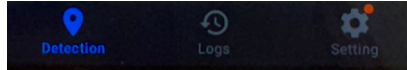

Figure 4.8 Function & Settings control bar

4.1.5 *System Operation Bar*

This control bar is divided into “return to the previous screen”, “return to home”, and “view open apps” functions.

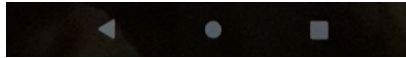

Figure 4.9 System operation control bar

AERSENTRY PATROL

4.2 | HISTORY

Historical Tracking Functionality

The AeroSentry Patrol includes a built-in historical tracking feature that records and stores UAV detection data for post-event review. Users can filter recorded data by time, detection type, and other parameters to streamline analysis.

Available functions include:

Track Playback – Visual replay of UAV flight paths

Data Analysis – Statistical breakdown of activity over time

Data Export – Download of historical records for reporting or evidential use

This feature is particularly useful for auditing incidents, assessing patterns, and generating intelligence reports.

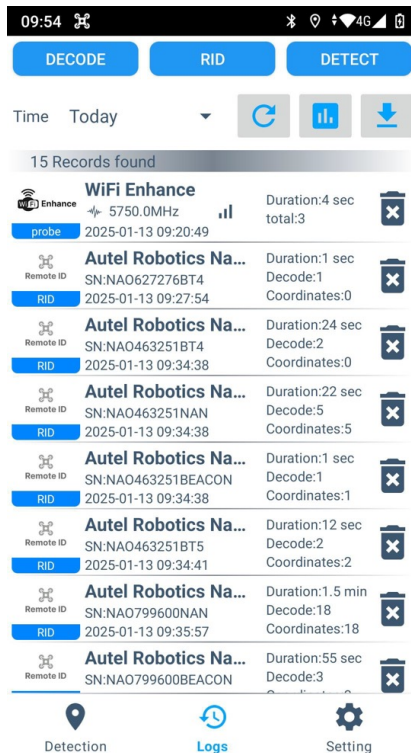

Figure 5 Historical data list

AEROSENTRY PATROL

4.2.1 *History List*

The History List displays a detailed record of previously detected UAV activity. Each entry includes:

- UAV icon and model
- Serial number (S/N)
- Duration of track
- Number of detections
- Time of detection
- Logged track points

Operators can filter playback results by detection type using the available filters: "**Resolve**", "**RID**", and "**Detect**". Selected filters are highlighted in blue.

To review specific events, use the time drop-down menu to select a relevant time window for playback.

AERSENTRY PATROL

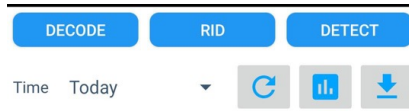

Figure 5.1 Conditional Screening

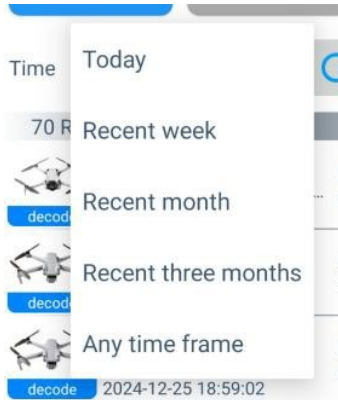

Figure 5.2 Time filter



Figure 5.3 Historical list

AEROSENTRY PATROL

4.2.2 Track Playback

To access historical flight data, select the “History” menu and choose a record from the track playback list. Clicking a record will open the playback interface. This interface displays detailed information on the selected UAV detection, including:

- Drone model
- Serial number (S/N)
- Detection time
- Duration of track

By selecting the drone or pilot icon on the map, users can view detailed metadata associated with the detection. Arrows on the map indicate the UAV’s direction of approach or movement.

Playback can be run at multiple speeds—1x, 2x, 4x, 8x, and 16x—allowing for quick review or detailed analysis of drone flight paths.

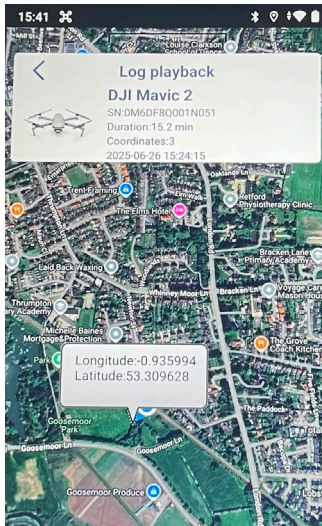

Note:

Track playback is only supported for UAVs classified under the “Decoding” or “RID” detection types. Detections listed solely under the “Detection” category do not include positional data and therefore cannot be played back.

AERSENTRY PATROL

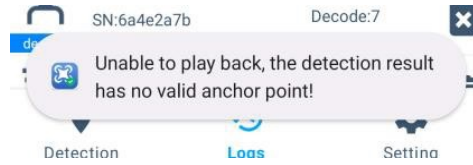

The track playback threshold is 100 meters. If the length of the track detected by the device is less than 100 meters, the track cannot be displayed

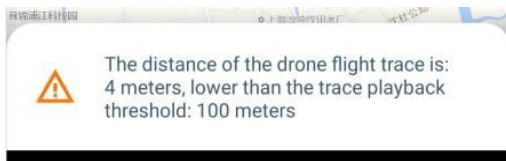

4.2.3 Data statistics

Click the “Statistics” button to see detection statistics.



Data Statistics and Analysis

The AeroSentry Patrol provides a built-in statistical analysis feature that allows users to review detection trends over time. The system can generate summary data on:

- Total number of UAVs detected
- Total number of detection events
- Breakdown of detections by UAV model
- Time-based distribution curves

These metrics can be filtered and analysed by specific time periods, supporting post-event analysis and operational planning.

AEROSENTRY PATROL

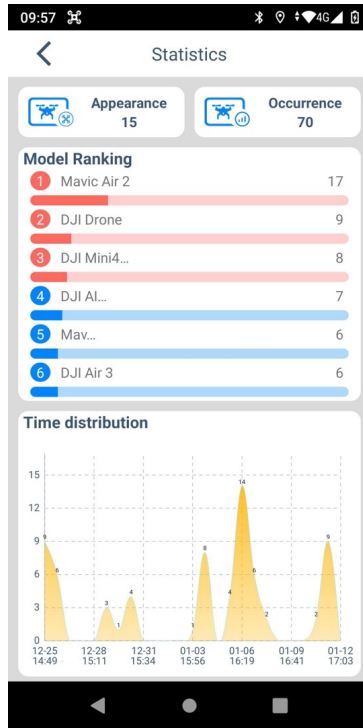

Figure 1 - Drone type distribution chart (top) and time distribution curve chart (bottom)

AEROSENTRY PATROL

4.2.4 Download

Click the "Download" option to export the data.



You can manage or transfer data via Bluetooth in:
"Settings > Application Management > Data File Management".

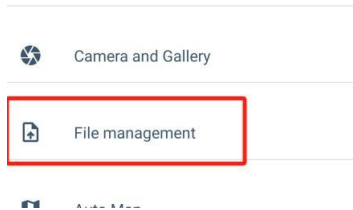

You can also clear the historical data by pressing one key in Settings About.

AERSENTRY PATROL

4.3 | System Settings

The AeroSentry Patrol offers a comprehensive system settings menu, allowing the operator to customise and manage the device according to operational requirements. The available settings include:

- General Settings
- Display Settings
- Network Configuration
- Alarm Settings
- Whitelist Management
- Location Settings
- Parameter Configuration
- Application Management
- Device Information

4.3.1 General Settings

The General Settings menu allows the user to:

- Switch between light and dark display themes
- Set the preferred application language
- Configure the system language for all interface elements

These options help tailor the device for local use and varying operational environments.

AERSENTRY PATROL

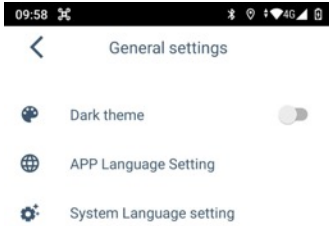

- You can switch between 'light' and 'dark' theme according to the actual use scenario.

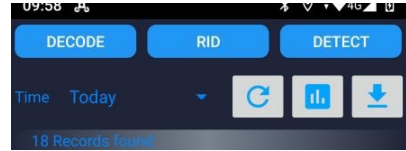

- Pull down from the top of the screen to control the menu, which can be adjusted at the top of the menu



- Click APP language settings to modify the APP language used in the APP, and switch the APP language according to the actual use scenario.



Figure Systems Settings - General Settings Interface

AEROSENTRY PATROL

The system language can be customised to suit the operator's preference. Multiple language options are available and can be manually added as required.

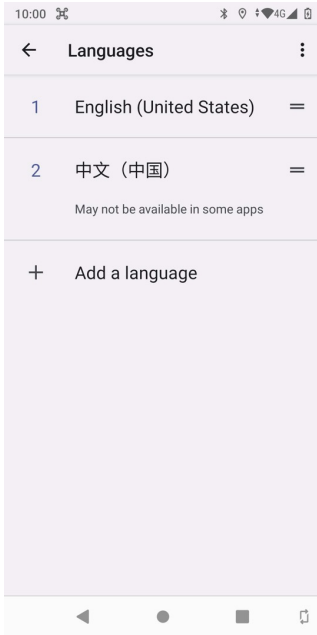

Hold the language bar and drag it to the first position to change the system language.



Figure Systems Settings - System Language Settings Interface

AERSENTRY PATROL

4.3.2 Display Settings

The Display Settings menu allows the user to configure visual behaviour and on-screen elements, including:

- Screen Activation: Toggle whether the screen remains on during operation
- Detection Normalisation: Enable automatic detection when the device is charging
- Map Icon Auto-Clear: Automatically remove UAV icons from the map after a set duration
- Icon Timeout Configuration: Define how long icons remain visible before being cleared

These settings allow the interface to be optimised for both operational clarity and power efficiency.

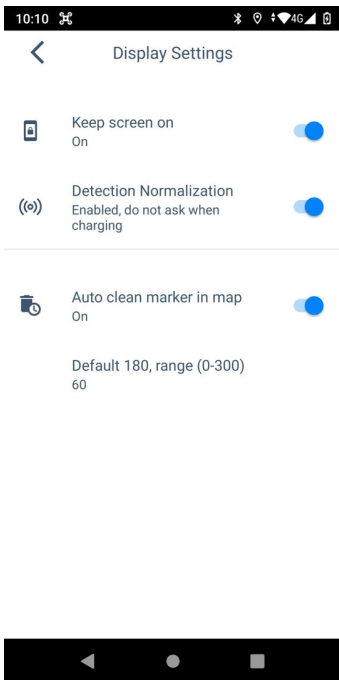

When 'Detection Normalisation' is enabled, the system will prompt the user to confirm whether detections should begin automatically when the device is connected to a power source and charging.

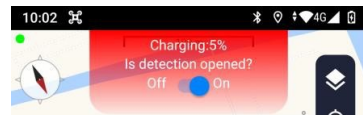

When 'Map Icon Auto-clear' is enabled, UAV trajectory icons will be automatically removed from the display after the specified time duration had lapsed. If a time value is set, icons will remain visible for that period before being cleared. If the feature is disabled, UAV icons and flight paths will remain on screen indefinitely.

Figure Systems Settings - Display settings interface

AERSENTRY PATROL

4.3.3 Network Settings

Select the Network Settings option to configure the device's connectivity. The AeroSentry Patrol supports both Wi-Fi and SIM-based mobile network connections.

Once a compatible SIM card is inserted, the device will allow manual configuration of mobile network settings to enable secure, field-ready connectivity without relying on external infrastructure.

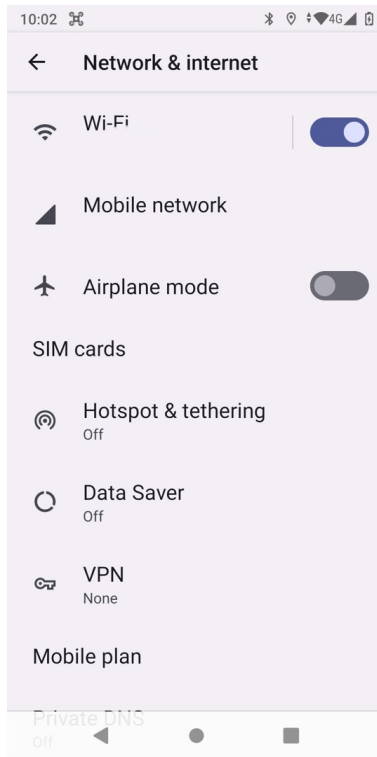

Figure Systems Settings - Network Settings Interface

AEROSENTRY PATROL

4.3.4 Alarm Settings

The Alarm Settings menu allows users to enable or disable various alert modes triggered by drone detection events. Available options include:

- Audible Alarm
- Vibration Alert
- Screen Flash Warning

Each mode can be toggled on or off independently, and multiple alert types may be activated simultaneously to suit different operational environments.

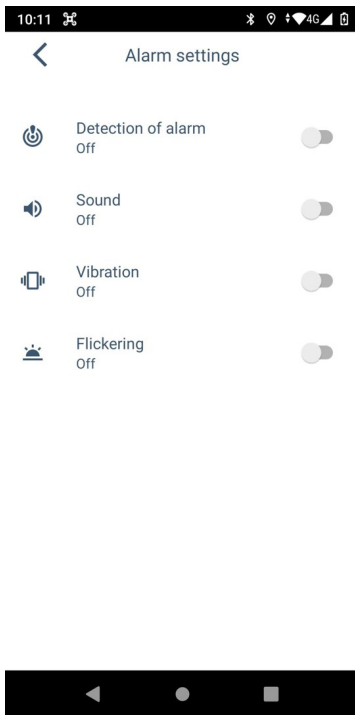

- **Sound alarm** - When enabled, the audible alarm will sound immediately upon drone detection, providing a clear indication of an unauthorised intrusion into the monitored airspace.

- **Vibration Alarm** - When this function is enabled, the device will vibrate to alert when a drone is detected.

- **Screen Flash Warning** - When enabled, the system will flash red light around the system interface, to alert when the system detects a drone.

Figure Systems Settings - Alarm Settings Interface

AERSENTRY PATROL

4.3.5 White List Settings

Select the **Whitelist Configuration** option to manage trusted drones. Within this interface, users can:

- Modify the **trust status** of individual drones
- Edit the associated **label or reference name** for easier identification

To remove all whitelisted entries, navigate to **Settings > About > Clear Whitelist** and use the one-click function to reset the list.

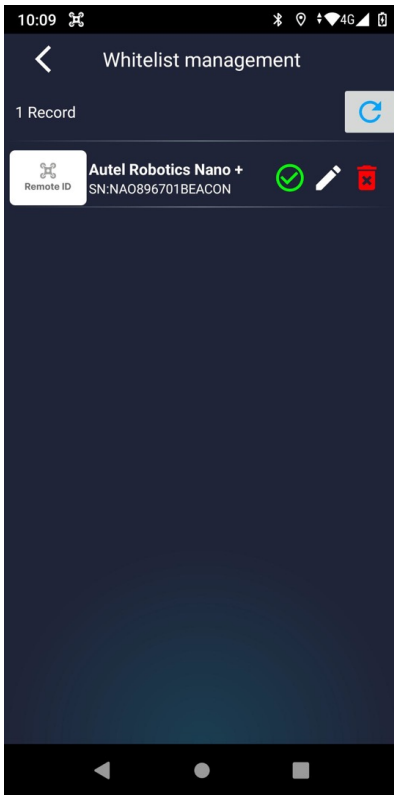

• Trust modification



• Note modification



• Data clearance

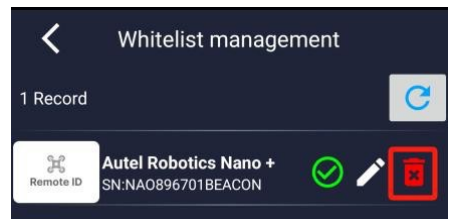

Figure Systems Settings - White List Management Interface

AERSENTRY PATROL

4.3.6 Location Settings

The Location Settings menu allows users to configure the device's fixed position on the electronic map.

When the "Lock Position" toggle is enabled, the AeroSentry Patrol will use the manually entered latitude and longitude coordinates as its fixed location within the system map—regardless of GPS signal.

This setting is useful in environments where GPS reception is unreliable or unavailable.

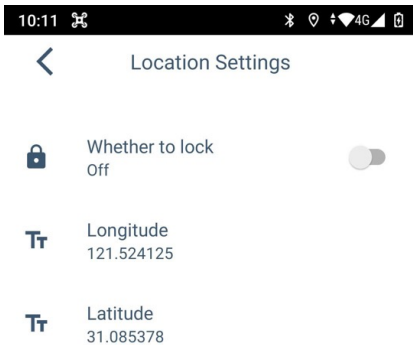

- **Function Declaration:**

When the device has no GPS signal, you can click on the map to set a temporary location.

When the device GPS is locked and normally obtains GPS information, you need to manually turn off the "lock"

- **Setup Method:**

- Open the location Settings.
- Engable 'Whether to lock' toggle.
- Find the area on the map, then hold down the area until the "Set Fixed Location" option box appears
- Click 'OK' to set it up.



Figure Systems Settings - Parameter

AEROSENTRY PATROL

4.3.7 Parameter Settings

The Parameter Settings menu provides advanced configuration options, including:

- Fan Control – Manage the device’s internal cooling system
- Detection Sensitivity – Adjust RF gain and signal detection thresholds
- Frequency List Configuration – Define which frequency bands are actively monitored for drone signals

These settings allow for performance tuning based on the operational environment.

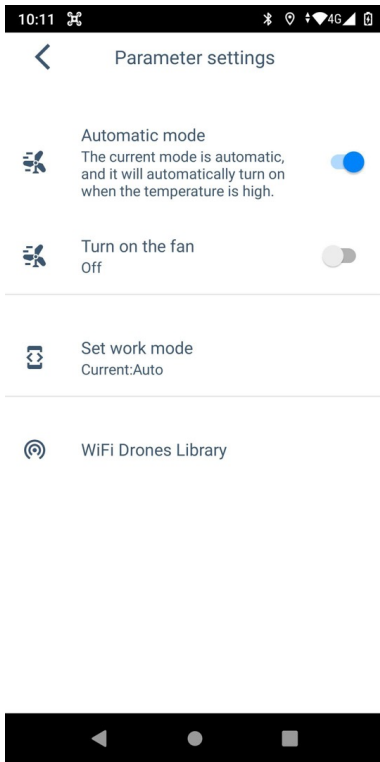

- **Fan control:**
When the automatic mode is turned on, the fan will automatically turn on when the device temperature is high; it can also be manually controlled by “open fan” to control the state of the fan.
- **Detection sensitivity:**
Can be controlled by the ‘Gain and detection’ sensitivity level
- **Frequency list:**
This the the corresponding frequencies for which a UAV can be detected.

Figure Systems Settings - Parameter settings

AEROSENTRY PATROL

4.3.8 Application Management

Application management includes: telephone, camera and library, data file management, map management, Nanshan intercom, interface setting, environment.

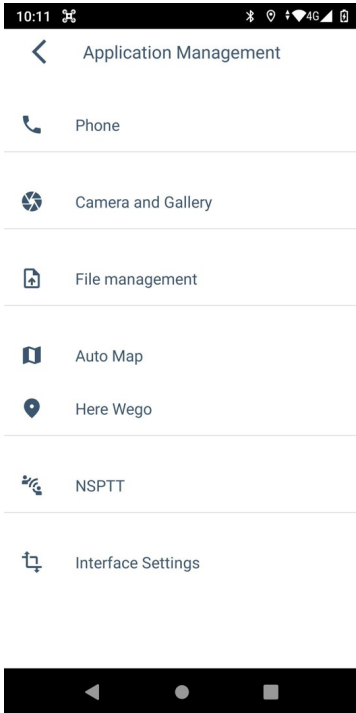

- **Telephone:**
This function can be used when a SIM card is inserted into the device.
- **Camera and Gallery:**
The device can take photos in real-time and transmit via Bluetooth.
- **Data file management:**
Manage and transmit historical data of relevant drones.
- **Map management:**
Display device navigation map.

Figure Systems Settings - Application management settings

AERSENTRY PATROL

4.3.9 About

The **About** section displays key system details and maintenance tools, including:

- **Debugging Log** – Real-time system operation log for diagnostics
- **Software Version** – Current firmware and application version number
- **Historical Data Overview** – Summary of stored detection records
- **Clear Whitelist** – One-click option to remove all trusted entries
- **Restart Application** – Manually restart the system software

When **Debugging Log** is enabled, live operational data will be shown within the electronic map interface. In the event of a system fault, these logs can assist in identifying the source of the issue.



Figure 4. System Settings - Debugging mode Settings Interface (left) and System main interface after debugging mode is turned on (right)

The **Version Information** panel shows the device model and current software version. It also includes a **Restart** button, which can be used to reboot the system if the detection programme becomes unresponsive

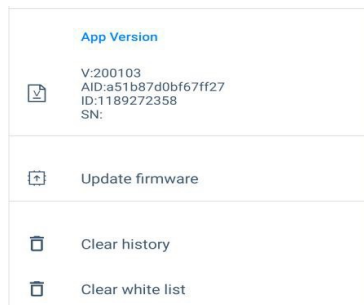

Figure System Settings - Device Versions and Other Features

AERSENTRY PATROL

4.4 | Core Function Introduction

4.4.1 Detection & Positioning Display

When a drone is detected, the main interface of the AeroSentry Patrol presents real-time telemetry on the GIS-based map. This includes:

- The drone's current position and flight path
- The geolocation of the drone operator (pilot)
- A live visual tracking overlay

A Drone Detection List will automatically appear below the map, showing real-time data such as:

- UAV model and serial number (S/N)
- Distance from the device
- Direction (azimuth) relative to the operator

By selecting the Drone Detection and Positioning List, the interface expands to show detailed telemetry for each detected UAV, including:

- Latitude and longitude of both the drone and pilot
- Directional bearing, speed, and altitude
- Technical specifications such as weight, maximum flight time, and control range

This detailed view supports rapid threat assessment and enhances situational awareness during active operations.

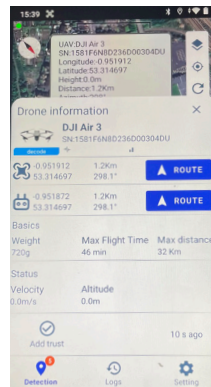
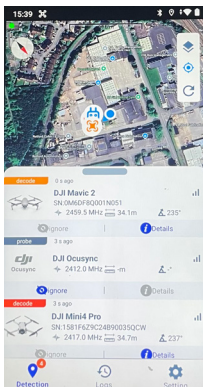

Figure 4.10 List of UAV detection and positioning (Left)

Detailed UAV information after clicking expand (Right)

AERSENTRY PATROL

4.4.2 Whitelist addition function

Trusted Drone Identification

The AeroSentry Patrol includes a whitelist function that allows authorised or known drones to be marked as trusted. Once a UAV is added to the whitelist, it will no longer trigger alarms or alerts when detected.

Adding to the Whitelist

To whitelist a drone, expand the Detection List on the main interface. Locate the relevant UAV entry and click the “Trust” button to designate it as a known asset.

Custom Labelling of Whitelisted Drones

After marking a UAV as trusted, the option to “Change Comments” will appear. This allows the operator to assign a custom label or note to the whitelisted drone for easy identification in future detections.



The process of adding drones to the whitelist:

1. Click on 'Add trust' and the icon will change to 'Trusted'
2. Click 'Change remarks'
3. Click on 'Settings - Whitelist'
4. Drone will now appear in whitelist



Figure 4.11 Whitelist addition interface diagram

AERSENTRY PATROL

4.4.3 Pilot position navigation function

To initiate navigation to a detected drone or pilot location:

1. Open the **Detection List** from the main interface and expand it to view detailed detection data.
2. Click on the **“Route”** option beneath the relevant entry.
3. This will launch the designated navigation application, allowing you to plan and follow a search route to the drone or pilot’s last known location.

This feature supports rapid response and ground team coordination in real-time tracking scenarios.

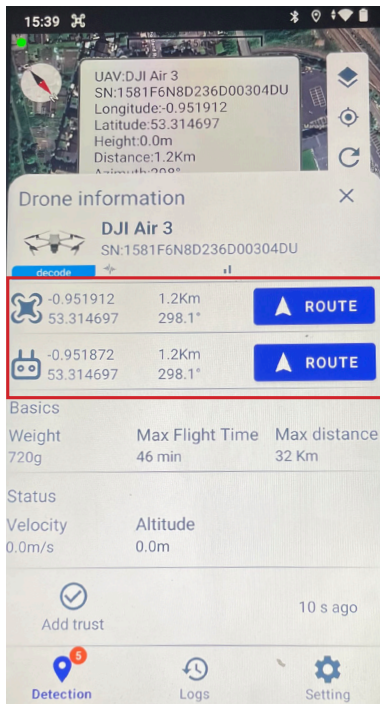

Location navigation process:

1. Click on 'Route' option (corresponding to the drone or pilot).
2. Jump to the navigation system and plan route.

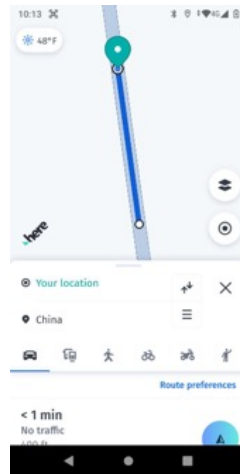

Figure 4.12 Navigation Interface of Drone or Pilot (remote control)

AEROSENTRY PATROL

5. PRODUCT PARAMETERS

5.1 SAFETY & STANDARDS

Model	H2L
-------	-----

5.2 ELECTRICAL CHARACTERISTICS

Charging interface	Type-C
Endurance	Approx 4.5 hours (with screen brightness of 20%)
Charging time	Approx 2.5 hours (with original charger)

Note: The battery life test conditions are that the device battery cycles less than 10 times, the ambient temperature is 25 degrees , and the screen brightness during the test is 20%. The specific battery life is subject to actual use.

5.3 MECHANICAL PARAMETERS

Size	185mm x 80mm x 33mm (LxWxH) +-5mm
Weight	580g +-10g (Including antenna)
Screen Specifications	6.0 inch
Screen Resolution	1080 x 2160 pixels

5.4 ENVIRONMENTAL ADAPTABILITY

Operation temperature	-25 degrees to +40 degrees
-----------------------	----------------------------

5.5 BATTERY PARAMETERS

Nominal capacity	8000mAh
Type	Built-in Lithium Battery

5.6 POWER ADAPTOR (ORIGINAL)

Input parameter	100 - 240V 50/60Hz 0.8A
-----------------	-------------------------

5.7 PACKAGING PARAMETERS

Size of protective box	335mm x 260mm x 130mm (=-2mm)
Net weight of protective box	2.56kg (+-0.1kg)



DRONEDEFENCE

DRONEDEFENCE.CO.UK

Drone Innovation Centre, Retford, DN22 7TX | +44 (0) 843 289 2805 | info@dronedefence.co.uk

www.dronedefence.co.uk